

Contents

1. **General**
 - 1.1 Information
2. **Hazard warnings**
 - 2.1 Safety related terms
 - 2.2 Safety advisory notice
 - 2.3 Qualified personnel
 - 2.4 Unauthorized alterations and spare parts
 - 2.5 Permissible operating mode
 - 2.6 Inadmissible operating mode
3. **Handling**
 - 3.1 Transport
 - 3.2 Storage
 - 3.3 Handling prior assembly
4. **Product specification**
 - 4.1 safety shut-off valve (OPSO)
 - 4.2 Pressure regulator 1st stage
 - 4.3 Pressure Relief Valve (PRV)
 - 4.4 Pressure regulator 2nd stage
 - 4.5 Emergency supply (Type 111)
5. **Connectors**
 - 5.1 Input connectors
 - 5.2 Output connectors
6. **Assembly**
 - 6.1 Information on hazards during installation, operation and maintenance
 - 6.2 Installation
 - 6.3 Leak test
7. **Operation**
 - 7.1 Initial commissioning
 - 7.2 Decommissioning
 - 7.3 Recommissioning
 - 7.4 Fault clearance OPSO (SAV)
 - 7.5 Maintenance
8. **Cause and remedy of operating faults**
 - 8.1 Fault detection
 - 8.2 Troubleshooting
9. **Repairs**
10. **Warranty**
11. **Drawing**
12. **Technical specifications**

1. General

Gas pressure regulators serve the purpose of reducing the outlet pressure to a predetermined constant value regardless of continuously changing flow rates and independently of changing inlet pressures.

These operating and installation instructions provide the information necessary to install and operate the container regulator combination type 110/111 safely and in the prescribed manner.

Should difficulties arise which cannot be solved by means of the operating instructions, further information should be obtained from the manufacturer.

These operating instructions comply with the relevant valid regulations and technical codes of the Federal Republic of Germany. When using the tank regulator combination type 110/111 outside the Federal Republic of Germany, the operator or the person responsible for the design of the plant must ensure that valid national regulations are observed. The manufacturer reserves all rights to make technical modifications and improvements at any time. The use of these operating and assembly instructions requires the user to be qualified as described in section 2.3 "Qualified personnel". The user must be instructed according to the operating and assembly instructions. The operating and assembly instructions must always be available at the place of use of the plant.

1.1 Information

The tank regulator combination type 110/111 consists of a 1st stage regulator and a 2nd stage regulator, which reduces the unregulated pressure from the LPG tank to a fixed set outlet pressure and keeps it constant. As safety equipment, an overpressure safety shut-off valve (OPSO) and an overpressure safety relief valve (PRV) are installed.

2. Hazard warnings

2.1 Safety related terms

The terms DANGER, CAUTION and NOTE are used in these operating instructions to indicate special hazards or unusual information that requires specification.



DANGER! means that non-observance can endanger life and/or cause considerable damage to property.



CAUTION! means that there is a risk of injury and/or damage to property if not observed.



NOTE! means that particular attention is drawn to technical issues.

However, compliance with other transport, assembly, operating and maintenance instructions and technical data not specifically highlighted are equally essential in order to avoid malfunctions which, in turn, may directly or indirectly cause personal injury or damage to property.

2.2 Safety advisory notice



DANGER! Liquid gas

- Highly flammable
- Can cause explosions
- Danger to persons through skin contact

2.3 Qualified personnel

All persons involved in the installation, commissioning, operation, maintenance and servicing of this pressure regulator must

- be appropriately qualified (specialist personnel)
- follow these operating instructions carefully
- consider the instruction manual as part of the product
- keep the instructions for use throughout the life of the product
- pass on the manual to any subsequent owner or user of the product



WARNING!

Danger of injury in case of insufficient qualification! Improper handling can lead to considerable personal injury and material damage.

2.4 Unauthorized alterations and spare parts

Modification or alteration of the tank regulator combination type 110/111 is not permitted. Original drawings and accessories authorised by the manufacturer serve for safety. The use of other parts or unauthorised modifications to the type 110/111 tank regulator combination by third parties invalidates the manufacturer's liability for the consequences.

2.5 Permissible operating mode

- liquid gas (gas phase), others on request
- ex zone 1 or 2
- under the container cover (above ground, underground), in weather-protected outdoor areas, in buildings and special installation rooms (according to TRF 2012)

2.6 Inadmissible operating mode

- ex-zone 0
- operating modes that deviate from the permissible operating modes and technical data

3. Handling

3.1 Transport

During all transportation, the generally recognised rules of technology and the accident prevention regulations must be strictly observed.

Handle the goods to be transported with care. During transport, the pressure regulator must be protected against shocks, blows or vibration.

Immediately after receipt of the goods, the delivery must be checked for completeness and transport damage. See also section 9.0.

3.2 Storage

If the pressure regulator is not installed immediately upon delivery, it must be stored properly.

Storage temperature -20°C to +60°C, dry, free of dirt and protected from moisture.

3.3 Handling prior assembly

- Protect from weather influences such as wetness
- Make sure that the product is free from dust and foreign particles

4. Product specification

4.1 Safety shut-off valve (OPSO)

The overpressure safety shut-off device OPSO is open during normal operation and is designed to shut off the gas flow automatically as soon as the set response pressure is reached in order to protect downstream equipment from impermissibly high pressure. It must be opened manually after closing (see OPSO restart).

4.2 Pressure regulator 1st stage

The 1st stage pressure regulator reduces the unregulated pressure from the liquid gas container to a set outlet pressure.

4.3 Pressure Relief Valve (PRV)

The PRV (Pressure Relief Valve) is closed during normal operation and is designed to automatically release the gas flow with limited flow when the pressure in the system to be protected reaches the set pressure. This is relieved via the regulator's venting port. It closes again automatically when the pressure drops below the set pressure.

The outlet opening must be protected against rainwater.



It is important to note that pressure regulators which are operated inside a building, an enclosure or a hazardous area must be provided with a vent line to the outside.



Please observe this information, otherwise liquid gas can escape in the building, which may lead to an explosion.



Insect screen with filter screen must be screwed into the vent on the regulator. It must be checked regularly whether the screen is free from dirt. A clogged screen can lead to increased or too low outlet pressures and thus to a response of the OPSO.

4.4 Pressure regulator 2nd stage

The pressure regulator of the 2nd stage reduces the output pressure of the pressure regulator of the 1st stage to a fixed output pressure of 50 mbar.

4.5 Emergency supply (Type 111)

If the gas tank should unexpectedly run out of gas, the gas supply can be secured by means of a gas cylinder via the emergency supply connection using a high-pressure hose. This is not a permanent solution. It only serves as a temporary solution until the gas tank is filled again.

5. Connectors

5.1 Input connectors

- Cylindrical female threads:
G.37 = G 1/4", G 3/8", G 1/2", G 3/4", G 1"
- Large cylinder connection:
G.4 = W 21,8 x 1/14 LH
- POL Connection:
G.9
- Cutting ring fitting RVS:
G.22 = 12mm, 15mm, 18mm, 22mm, 28mm

Other connections on request!

5.2 Output connectors

- Cylindrical female threads:
H.22 = G 1/4", G 3/8", G 1/2", G 3/4", G 1"
- Cutting ring fitting RVS:
H.8 = 12mm, 15mm, 18mm, 22mm, 28mm
- Compression fitting PVS:
H.10
- Soldering screw connection LVS:
H.10

6. Assembly

6.1 Information on hazards during installation, operation and maintenance



DANGER!

Safe operation of the pressure regulator is only guaranteed if it is installed and commissioned by qualified personnel (see point 2.3 "Qualified personnel") in accordance with the warnings in this operating manual. Proper use of tools and protective equipment must be ensured. The operating instructions of the pressure regulator must be observed during all work on the pressure regulator or when handling the pressure regulator.

6.2 Installation

In addition to the generally applicable installation guidelines, the following points must be observed:

- current TRF (private area)
- accident prevention regulation DGUV 79 +80 (commercial sector)
- corresponding DVGW worksheets



NOTE!

The installation position of the pressure regulator must be carried out according to the enclosed support device. It is also important to note that the installation position of the vents must be selected in such a way that any water accumulation can drain off.



The interior of the pipeline must be free of foreign particles.

A tension-free installation must be ensured.

The pressure regulator must not serve as a fixed point; it is supported by the pipeline system.

Observe flow direction (marked by an arrow on the product).

The pressure regulator must be mounted and protected in such a way that dripping water cannot penetrate. When mounting on an underground liquid gas tank, we recommend a ventilation set (art. no.: 9 03 110 8 5 000 2). If the pressure regulator is used outdoors, it must be mounted under the protective cover or in a protective box.

- When tightening the POL connection, avoid any force on the pressure regulator.
- Prevent sealant from penetrating the gas-carrying components.
- For threaded connections, always use a suitable spanner to counteract.
- After assembly a careful leak test must be carried out.

6.3 Leak test



CAUTION: The control device must not be included in a strength test (design review) of the entire installation.

- Close all shut-off valves of the connected devices.
- apply test pressure according to TRF 2012
- wait for temperature adjustment
- test duration 10 minutes (the pressure must not drop)
- spray all connections with foaming agents (e.g. leak detection spray) and check for leaks



NOTE!

We recommend the leak test with our testing device (Art. No.: 1 00 098 14 018 2)



DANGER!

Before each commissioning of a new installation or recommissioning of an installation after repairs or modifications, the following must be ensured:

- proper completion of all installation/assembly work!
- commissioning only by "Qualified personnel "(see point 2.3).
- passed leak test

7. Operation

7.1 Initial commissioning

After completion of the leak test the pressure regulator is ready for operation.

7.2 Decommissioning

If the supply and consumption system is to be taken out of operation, all shut-off valves must be closed and the pipe system drained. All open connections must be secured with a suitable seal.

7.3 Recommissioning

When recommissioning the regulator, make sure that all the relevant steps are repeated as described in section 6.1 to section 6.3.

If recommissioning is not possible, the manufacturer must be informed.

7.4 Fault clearance OPSO (SAV)

If the OPSO has locked, indicated by the visual indicator (red), the following steps are required:

- Close the tapping valve on the liquid gas container
- Relieve the pressure on the pressure regulator (on the inlet and outlet side)
- Turn off the OPSO display
- Place the OPSO plunger with the enclosed lever tool on the red indicator and pull it out until it engages
- After rectifying the fault, open the gas outlet valve

7.5 Maintenance

If the points in section 6 are observed, the pressure regulator is maintenance free.

8. Cause and remedy of operating faults

8.1 Fault detection



DANGER!

When troubleshooting, the hazard warnings under 2 must be observed.

- If the faults cannot be rectified using the following table "Troubleshooting (8.2)", the manufacturer must be consulted.
- In case of malfunctions of the function or the performance, it must be checked whether the installation work has been carried out and completed according to these operating instructions.
- The information on pressure, temperature, and direction of flow as well as the operating conditions must correspond to the data sheet or the technical data on the type plate

8.2 Troubleshooting

Fault	Measures
Gas smell Caution: Fire and explosion hazard!	Keep calm, close the gas supply, open windows and doors, do not operate any electrical switches, contact a specialist
No gas flow	Open shut-off valves, check level indicator if necessary, OPSO is closed (see Recommissioning OPSO), check the filter in the inlet connection as well as the vent openings and clean if necessary or contact the manufacturer.
Consumption appliance on fault	After depressurising the system, connect the "Müller test unit" to the appropriate test connections on the regulator and take measurements: <ul style="list-style-type: none"> • inlet pressure (upstream pressure before the controller stage) • outlet pressure (idle pressure, consuming device not in operation) • outlet pressure (flow pressure, consumer unit in operation) • connection pressure at the consumer unit <p>Then compare the values with the technical data of the regulator and the consumer unit.</p>

Fault	Measures
OPSO falls continuously or cannot be unlocked	Pressure regulator is defective, please replace.

 **NOTE!**
Before carrying out assembly and repair work, please observe Section 10

9. Repairs

In order to ensure the proper functioning of the installation under normal operating conditions, it is recommended to replace the device before 10 years have elapsed since the date of manufacture.

The 10 years is a recommendation that can be replaced by national laws or technical regulators, taking into account the operating conditions of integrated safety devices and maintenance schedules.

According to DGUV 79:

The Contractor must ensure that parts of consumable equipment that are subject to wear and aging are replaced after a maximum of 8 years. This does not apply if the proper condition has been confirmed by an expert.

10. Warranty

The scope and period of warranty is defined in the version of the "General Terms and Conditions" of Müller Gastechnik GmbH valid at the time of delivery.

All information and notes in this manual have been compiled taking into account the applicable standards and regulations, the state of the art and our many years of expertise and experience. The manufacturer accepts no liability for damages due to:

- Non-compliance with the instructions
- Unintended use
- Use of untrained personnel
- Unauthorised conversion
- Technical changes
- Use of non-approved spare parts. The actual scope of delivery may differ from the explanations and illustrations described here in the case of special versions, the use of additional ordering options or due to the latest technical changes.

11. Drawing (BRK-110/111)

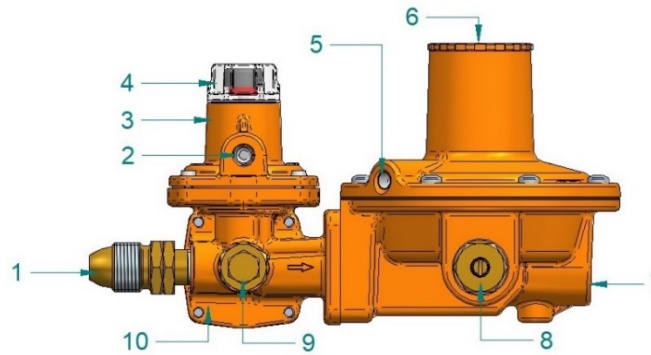

1. inlet connection Pol
2. OPSO (SAV) vent opening
3. overpressure safety shut-off device OPSO (SAV)
4. visual display OPSO
5. ventilation outlet regulator (connection for insect screen) Internal overpressure safety relief valve
6. low pressure regulator 2nd stage
7. outlet connection G 1/2 "IG
8. test device back pressure, 8mm hose connection from "Müller test device"
9. test device inlet pressure G 1/4" (for type 111 via emergency supply connection G 3/8" LH-KH
10. medium pressure regulator 1st stage

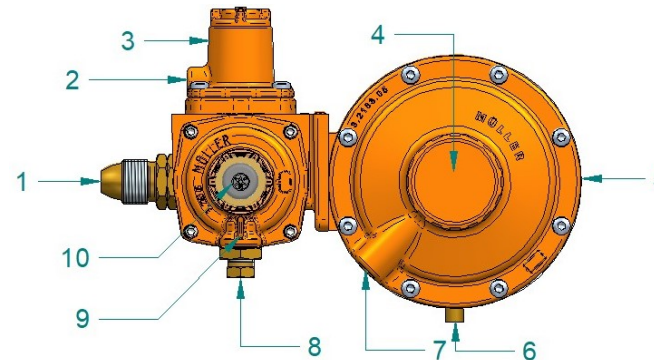

1. inlet connection Pol
2. ventilation opening medium pressure regulator
3. medium pressure regulator 1st stage
4. low pressure regulator 2nd stage
5. outlet connection G 1/2 "IG
6. test device back pressure, 8mm hose connection from "Müller test device"

7. ventilation blow-off opening regulator (connection for insect screen) internal overpressure safety blow-off valve
8. test device inlet pressure G 1/4" (for type 111 via emergency supply connection G 3/8" LH-KH
9. vent opening OPSO (SAV)
10. visual display OPSO

12. Technical specification (BRK-110/111)

Max. permissible pressure:	PS 25	Response pressure OPSO:	132 mbar
Nominal flow Mg:	10 kg/h	Response pressure PRV:	150 mbar
Inlet pressure p:	3-16 bar	Connection at inlet	Pol
Nominal outlet pressure pd:	50 mbar	Connection at outlet	G 1/2"
Pressure loss:	ΔP 5	Temperature range	-40 °C to +80 °C